

CITY OF WESTMINSTER			
PLANNING APPLICATIONS SUB COMMITTEE	Date 14 April 2020	Classification For General Release	
Report of Director of Place Shaping and Town Planning		Ward(s) involved Marylebone High Street	
Subject of Report	9 Marylebone Lane, London, W1U 1DA		
Proposal	Amendments to planning permission dated 26 September 2014 for the demolition of existing building and redevelopment to provide a building comprising lower ground, ground and seven floor levels, excavation to provide three sub-basement levels. Use of the building as 21 residential units, terraces at sixth and seventh floors, together with landscaping of existing access road, landscaped communal amenity space. Associated ancillary leisure facilities, car and cycle parking, mechanical plant and associated works at lower basement levels; NAMELY, to enable amendments to the design and size of the internal window fins.		
Agent	DP9		
On behalf of	Clivedale Properties Ltd		
Registered Number	19/06758/NMA	Date amended/ completed	17 February 2020
Date Application Received	28 August 2019		
Historic Building Grade	Unlisted		
Conservation Area	Outside conservation area.		

1. RECOMMENDATION

Agree non-material amendment.

2. SUMMARY

Planning permission was granted on 26 September 2014 for the redevelopment of 9 Marylebone Lane to provide an eight-storey building comprising 21 residential units. The approved scheme included internal and external privacy fins to some rear windows to prevent overlooking to neighbouring properties. The development was completed with external privacy fins but without any internal fins. This application seeks an amendment to the scheme to alter the design of the internal fins by way of Section 96a of the Town and Country Planning Act 1990. This procedure enables applicants to make small changes to a previously approved scheme without the need for a new planning application.

The one issue in this case is whether the revised design of the internal window fins is materially different to that originally approved. In this case, whilst the revised fins are marginally smaller, it is considered that, in the context of the overall scheme, this is a non-material amendment.

3. LOCATION PLAN

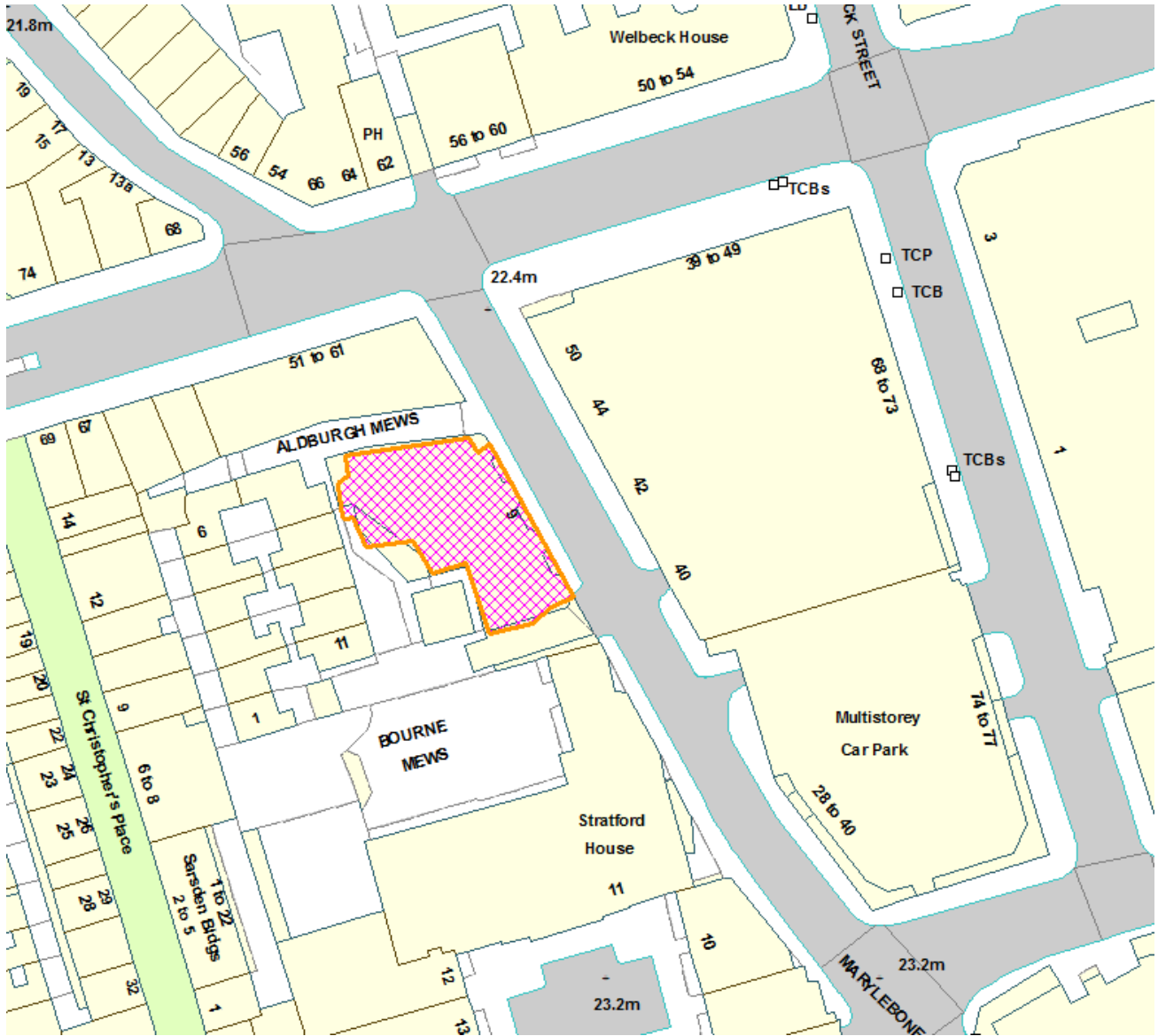

This production includes mapping data licensed from Ordnance Survey with the permission of the controller of Her Majesty's Stationary Office (C) Crown Copyright and /or database rights 2013.

4. PHOTOGRAPHS

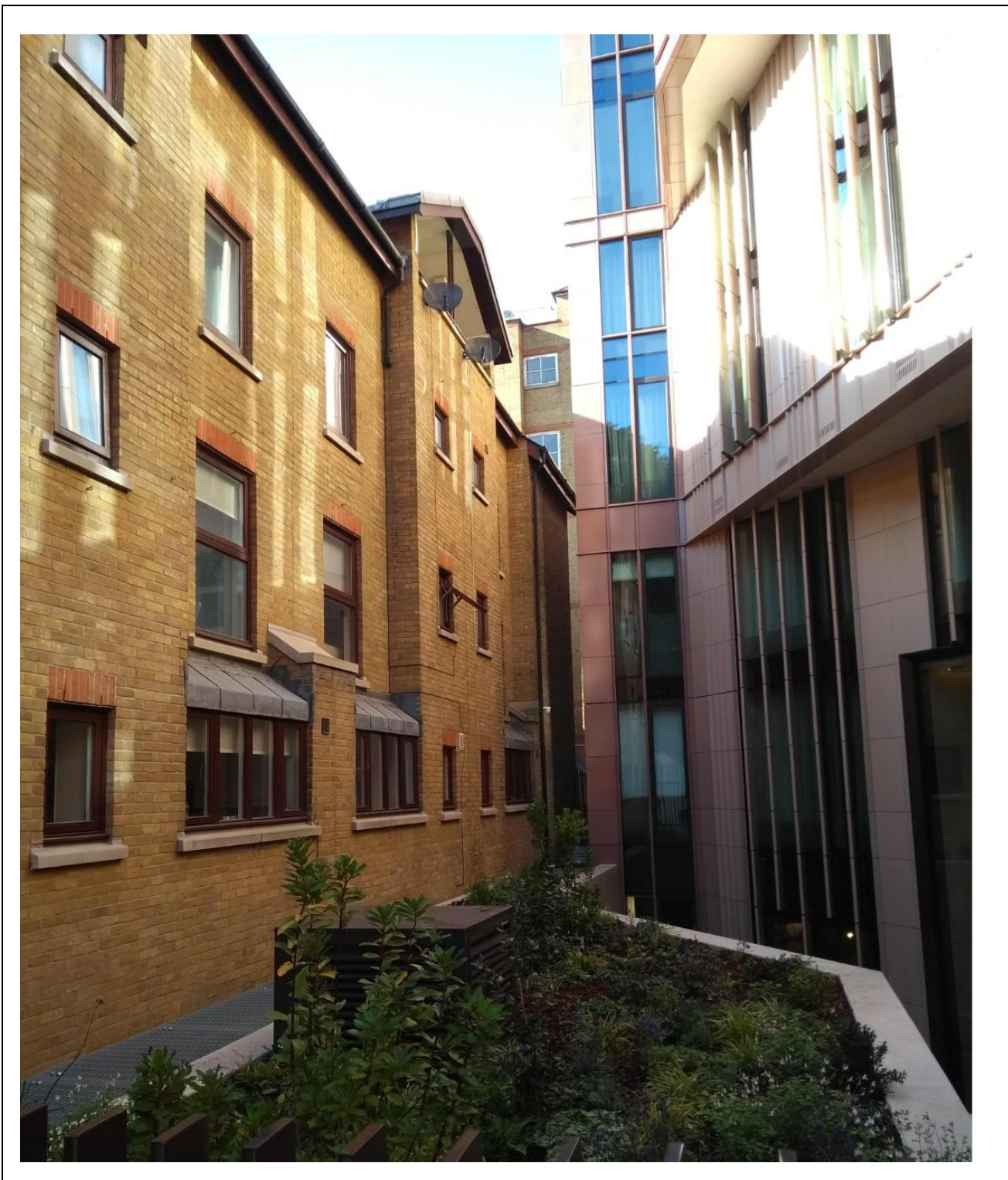

5. CONSULTATIONS

As an application under Section 96A of the Town and Country Planning Act 1990, this is not an application for planning permission. Therefore, the existing provisions under the Town and Country (General Development Procedure) Order 1995 (as amended) in respect of planning applications do not apply. Neighbour notifications are not normally sent. However, given the circumstances of this application, the immediate neighbours have been notified.

ADJOINING OWNERS/OCCUPIERS AND OTHER REPRESENTATIONS RECEIVED

No. consulted: 11; Total no. of replies: 5 (from 2 respondents)

5 letters of objection on the following grounds:

- * Existing fins are not effective in providing privacy
- * The proposed amendments are materially different from the approved scheme
- * A mock-up of the proposed fins should be installed
- * Concern that the developer has had no intention of fitting internal fins and there is no apparent means of attaching further external fins
- * All privacy in neighbouring homes has been lost, contrary to human rights
- * The original application stated that there would be no overlooking to and from the proposed building and that the proposed fins would ensure that there were no views from within the new flats to neighbours' rooms

Other issues raised:

- * A request for additional time for residents to understand the proposals
- * Inadequate information has been submitted

PRESS ADVERTISEMENT / SITE NOTICE:
N/A

6. BACKGROUND INFORMATION

6.1 The Application Site

The application site is located on the eastern side of Marylebone Lane with frontages on Bourne Mews and Aldburgh Mews. It is a residential building, on three basement levels, lower ground, ground and seven upper floors built pursuant to planning permissions granted in 2014.

6.2 Recent Relevant History

Permission was granted on 10 April 2014 for the demolition of existing building and redevelopment to provide a building comprising lower ground, ground and seven floor levels, excavation to provide three sub-basement levels. Use of the building as 21 residential units, terraces at sixth and seventh floors, together with landscaping of existing access road, landscaped communal amenity space. Associated ancillary leisure facilities, car and cycle parking, mechanical plant and associated works at lower basement levels.

The approved scheme includes internal and external window fins, both 20cm in depth, to windows on the rear façade, up to third floor level. These fins were designed to minimise potential overlooking to the rear of neighbouring houses in Aldburgh Mews.

Further permission was granted 26 September 2014 for the variation of conditions 1, 5, 7, 8, 9, 12 & 21 of planning permission dated 10 April 2014 (RN:13/07854/FULL) to enable alterations to the approved layout of the residential flats; changes to car and cycle parking, changes to basement levels, photovoltaics and refuse areas, and minor external alterations including the repositioning of the windows and fins to correspond with the revised flat layouts.

Condition 9 of both permissions states “*The internal and external fins as shown on the approved drawings, must remain in situ for the lifetime of the development.*”

Condition 3 of both permissions also required the submission of detailed drawings of the typical bays of the building facades, at all levels. Detailed drawings to discharge this condition, including detailed drawings of the external privacy fins, were submitted and approved in June 2017 (under RN: 17/05360/ADFULL). The approved drawings show larger external fins measuring 50 cm in depth (including fixing bracket) and tapering in width from 8.6cm to 4.8cm (approx.).

In November 2018 a complaint was received on the grounds that the internal window fins had not been installed. This complaint is the subject of current enforcement investigations.

THE PROPOSAL

The development was completed with the installation of external fins to rear windows, but without providing the internal privacy fins, which were designed to further reduce potential overlooking between the new development and neighbouring homes. The applicant wishes to amend the approved scheme to revise the detailed design of the internal fins by way of Section 96a of the Town and Country Planning Act 1990 (as amended). This procedure, introduced in 2009, enables applicants to make small (non-material) changes to a previously approved scheme without needing to make a new planning application.

There is no statutory definition of what constitutes a ‘non-material’ change to a planning permission. The National Planning Practice Guidance (NPPG) states that the assessment is dependent upon the context of the overall scheme and that “what may be non-material in one context may be material in another”. Section 96A of the Planning Act states that “in deciding whether a change is material, a local planning authority must have regard to the effect of the change, together with any previous changes made under this section, on the planning permission as originally granted.”

The original fin design, as shown in the approved Design and Access Statement, shows internal fins measuring 20cm in length and tapering between 4 and 6cm in width (as shown below).

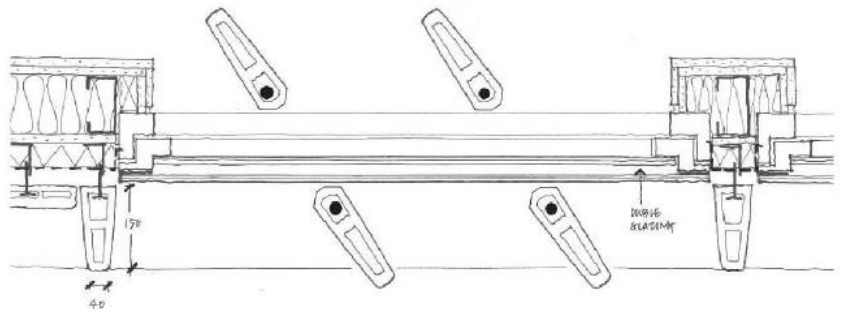

Preliminary plan detail of angled fins

The current application originally proposed an internal window fin measuring 14 cm in length. The application has since been revised to increase the length of the proposed window fin, to 17cm, tapering in width between 4cm and 1.5cm. The fins would be full height (floor-to-ceiling), made from solid timber and fixed to the ceiling transom.

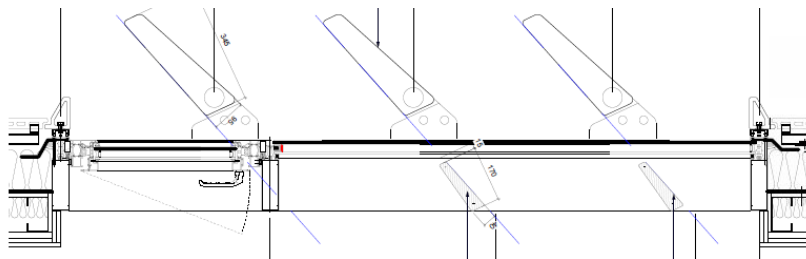

7. DETAILED CONSIDERATIONS

7.1 Land Use

The application does not raise any land use issues.

7.2 Townscape and Design

The revised design of the internal fins does not materially affect the appearance of the building.

7.3 Residential Amenity

The key issue is whether the amendment to the internal fin design is sufficiently minor as to constitute a non-material amendment to the approved scheme. Objections have been received from two residents of Aldburgh Mews on overlooking/privacy grounds.

One objector considers that an acceptable solution could be reached with the developer, and requested that a 'mock up' of the proposed internal fin be installed to demonstrate that their concerns regarding overlooking would be addressed by the revised design. They have not commented on the amended proposals.

The second objector continues to raise strong objections to the new design. They consider that the proposed alteration to the design of the internal window fins is a material change to the approved scheme, that there should be no change from the approved design and that smaller fins should not be considered acceptable. They have requested that the developer produce a sample fin/'mock up', to demonstrate that the proposed design would overcome current concerns about overlooking between the buildings, and have also requested that Members of the Planning Committee defer making any decision until they have undertaken a site visit.

A 'mock-up' of a 14cm long internal fin has been produced and photographs of this sample fin, in situ, have been provided. The developer has declined to provide a further sample of the longer fin now proposed (17 cm) but, instead, has produced fin comparison studies. These are designed to show the 'angle of view' between the buildings with the fins 'as approved' and as now proposed. This study shows that the larger external fins, as installed, and the internal fins, as now proposed, would further reduce the potential for overlooking between the buildings when compared with the original scheme.

The objector considers that this fin analysis study is incorrect, and is intended to mislead. They have referred to the applicant's original Design and Access (D&A) report which states that the original fin proposals were specifically designed with "deeper and angled louvres to ensure no overlooking to and from the proposed building... specifically, this means developing a deeper and angled variation to the standardised high-quality ceramic fins to be located across areas of glazed frontage where local overlooking poses a challenge. The orientation of these fins will ensure that whilst allowing adequate natural light into the building, there are no views possible from within the room to the adjoining neighbours' rooms and vice versa."

However, despite the assertion in the applicant's D&A Statement, the original committee report makes it clear that, even with both the internal and external fins shown, there would be some potential for overlooking between the two buildings. It states, the "fins are proposed over a majority of the rear elevation to minimise the amount of overlooking from the new residential flats to the existing mews houses. The fins will be deep and angled away from the mews windows to prevent direct overlooking. It is considered that this is an adequate solution to minimise overlooking."

There is no statutory definition as to what type of change might be considered to constitute a non-material amendment and this assessment will depend upon the circumstance of each case, with the decision made by the local planning authority. In this case, the approved internal and external fins both measure 20 cm in length (total depth 40cm). The proposed internal fins now measure 17cm in length but the external fins, (as approved under 17/05360/ADFULL) are 50cm long (including fixing bracket) (total 57 cm). In the context of the scheme, as both permitted and as implemented, the change to the size and design of the internal fins is considered to be de minimis. It is therefore concluded that the amendments are non-material and the application is therefore recommended for approval.

A condition is proposed to ensure that the internal fins are installed within an appropriate timescale.

7.4 Transportation/Parking

Not relevant in the determination of this application.

7.5 Economic Considerations

No economic considerations are applicable for a development of this size.

7.6 Access

Not relevant.

7.7 Other UDP/Westminster Policy Considerations

None.

7.8 Westminster City Plan

The City Council is currently working on a complete review of its City Plan. Formal consultation on Westminster's City Plan 2019-2040 was carried out under Regulation 19 of the Town and Country Planning Act (Local Planning) (England) Regulations 2012 between Wednesday 19 June 2019 and Wednesday 31 July 2019 and on the 19 November 2019 the plan was submitted to the Secretary of State for independent examination. In the case of a draft local plan that has been submitted to the Secretary of State for Examination in Public, under Regulation 22(3) of the Town and Country Planning Act (Local Planning) (England) Regulations 2012, having regard to the tests set out in para. 48 of the NPPF, it will generally attract very limited weight at this present time.

7.9 Neighbourhood Plans

None relevant.

7.10 London Plan

This application raises no strategic issues.

7.11 National Policy/Guidance Considerations

The City Plan and UDP policies referred to in the consideration of this application are considered to be consistent with the NPPF unless stated otherwise.

7.12 Planning Obligations

Planning obligations are not relevant in the determination of this application.

7.13 Environmental Impact Assessment

Not applicable.

7.14 Other Issues

The objector initially raised concerns on the grounds that inadequate time had been given for residents to understand the proposals and that inadequate information had been submitted. The submitted details are considered sufficient to understand the current proposals and it is considered that neighbouring residents have had enough opportunity to consider the proposals and to submit any comments.

One objection has been received on the grounds that the proposals would result in a fundamental loss of privacy contrary to Article 8 of the Human Rights Act. The Human Rights Act requires that the City Council in its role as local planning authority acts consistently with the European Convention on Human Rights.

Article 8 rights are not rights without limit and may be interfered with where it is in accordance with the law and is necessary in a democratic society. Article 8 rights should be respected as part of the planning process, but they are not guaranteed and it is a planning judgement against all the other material considerations, wider public interests and other private interests. Article 8 does not give a right to a home but, where someone has a dwelling, it may interfere with their Article 8 rights to require them to move from that home. As the Town and Country Planning regime is designed to balance the rights of individuals against the interests of the wider community, the City Council must consider the potential interference with human rights and ensure that any reasons for interfering with these rights are proportionate.

The rights of family, the applicant and the interests of the wider community have to be balanced when assessing this application. The impact of the proposal on neighbouring properties has been set out within the committee report. It is not considered that the proposal would require the objector to move from their home. It is therefore considered that any interference with the family's rights is proportionate.

(Please note: All the application drawings and other relevant documents and Background Papers are available to view on the Council's website)

IF YOU HAVE ANY QUERIES ABOUT THIS REPORT PLEASE CONTACT THE PRESENTING OFFICER: SARA SPURRIER BY EMAIL AT sspurrier@westminster.gov.uk

8. KEY DRAWINGS

Proposed fin (section and plan)

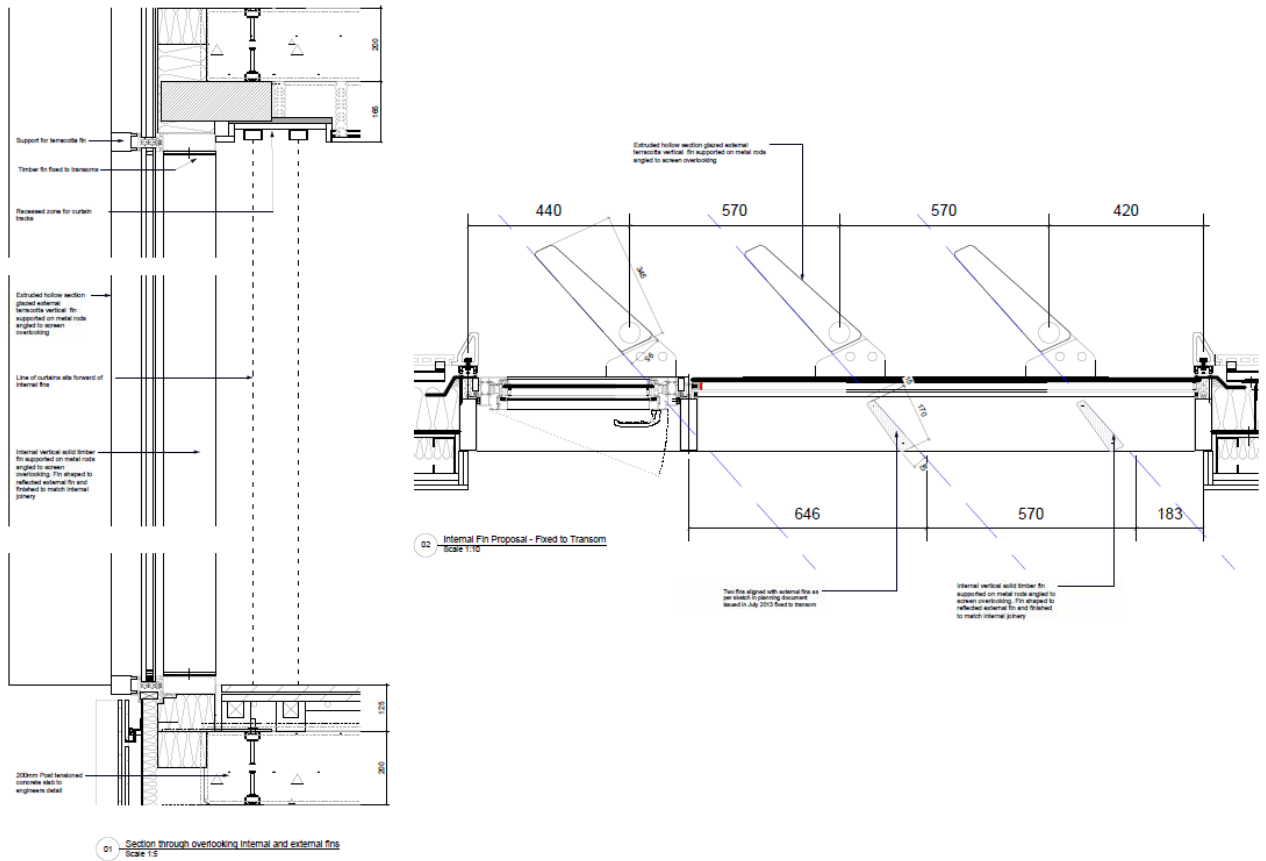

Proposed first floor plan

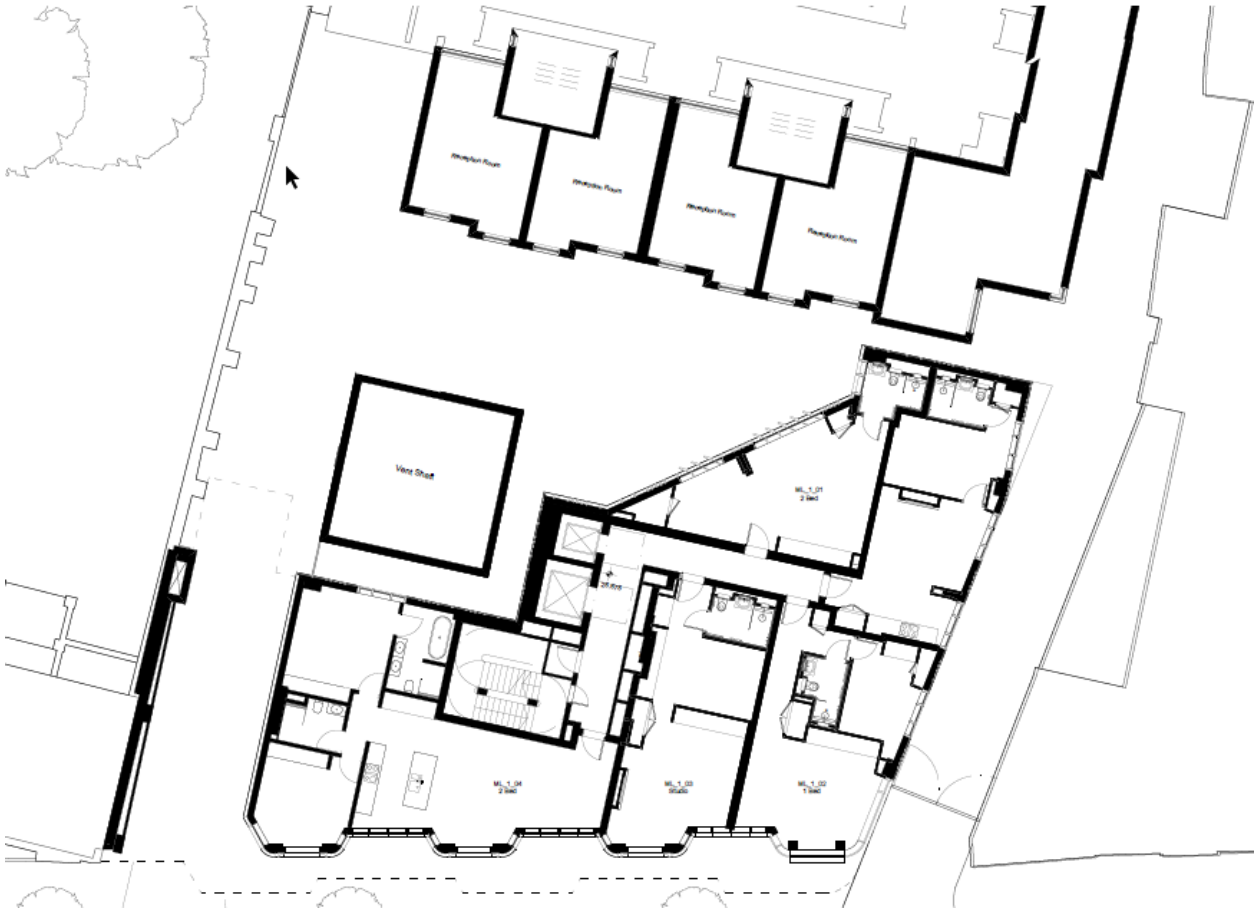

Fin comparison study

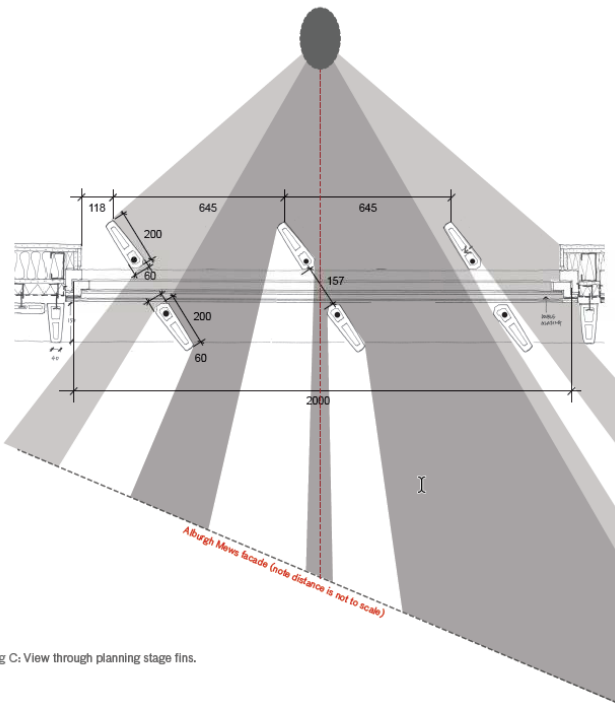

Fig C: View through planning stage fins.

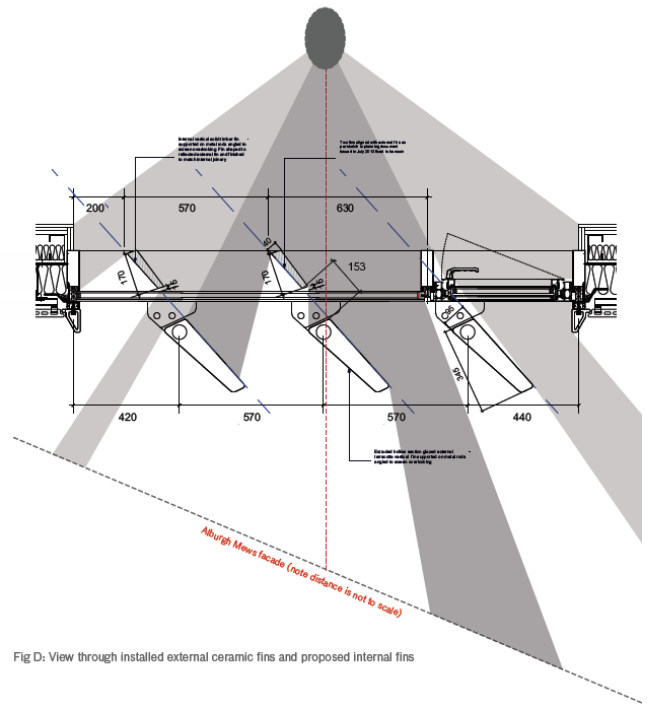
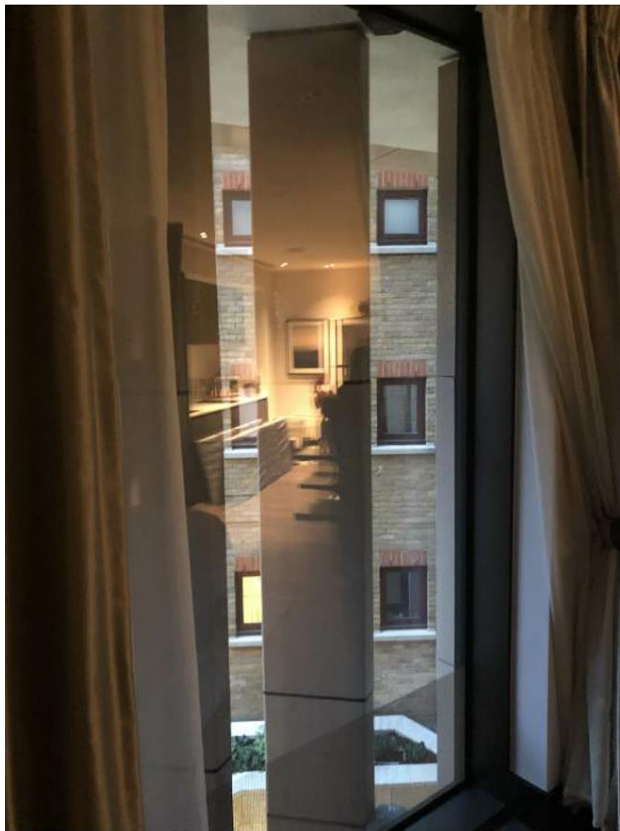

Fig D: View through installed external ceramic fins and proposed internal fins

Current view from Apartment 1.01



View from Apartment 1.01 with 14 cm fins in place



DRAFT DECISION LETTER

Address: 9 Marylebone Lane, London, W1U 1DA,

Proposal: Amendments to planning permission dated 26 September 2014 for the demolition of existing building and redevelopment to provide a building comprising lower ground, ground and seven floor levels, excavation to provide three sub-basement levels. Use of the building as 21 residential units, terraces at sixth and seventh floors, together with landscaping of existing access road, landscaped communal amenity space. Associated ancillary leisure facilities, car and cycle parking, mechanical plant and associated works at lower basement levels; NAMELY, to enable amendments to the design and size of the internal window fins.

Reference: 19/06758/NMA

Plan Nos: 225_20.15, 20.16, 20.17, 20.18; 225_SK.720 Rev D

Case Officer: Jo Palmer

Direct Tel. No. 020 7641
07866040238

Recommended Condition(s) and Reason(s)

- 1 The internal window fins, as shown on the approved drawings, must be installed in their entirety within x months of the date of this decision. They must thereafter remain in situ for the lifetime of the development.

Reason:

To make sure that the development does not affect people using the neighbouring properties next door as set out in S29 of Westminster's City Plan (November 2016) and ENV 13 of our Unitary Development Plan that we adopted in January 2007. (R02HC)

Please note: the full text for informatives can be found in the Council's Conditions, Reasons & Policies handbook, copies of which can be found in the Committee Room whilst the meeting is in progress, and on the Council's website.